

RVG and RVG-ST

Rotary Gas Meters



Applications

Media: Natural gas, town gas, propane, inert gases

Industry: Gas supply, stove manufacturers, chemical industry.

Tasks: Measurement, control and automatic regulation.

Brief information

RVG: Flange connection G16 – G400

RVG-ST: Standard thread connection G10 – G25

Operating principle: Elster-Instromet RVG and RVG-ST rotary gas meters are volume-measuring devices for gaseous media and operate according to the positive displacement principle.

They register the gas volume under operating conditions. In order to correct the measured volume to standard conditions, electronic volume correctors with various characteristics are available.

The actual measuring cell consists of two 8 shaped impellers, which build together with the housing 4 chambers per revolution, which are periodically filled and emptied.

The number of revolutions is proportional to the passed volume. The rotation is transferred to a mechanical index, which indicates this volume.

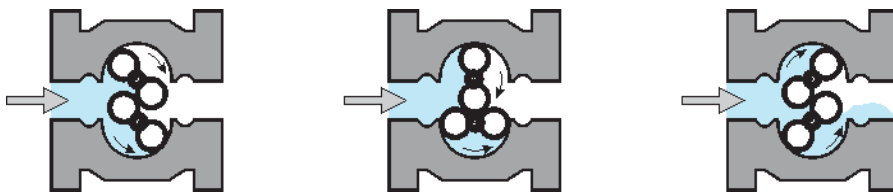

General: Rotary meters are characterized by high measuring range and compact dimensions.

Due to their measuring principle they do not require any straight inlet or outlet pipe section. Rotary meters have to be lubricated with oil. For easy access and control of the appropriate oil level the oil chambers on the front and the backside are connected to allow maintenance to be done from the front side only.

The double direction index allows adapting the meter to any flow direction.

The RVG is available with the latest technology of the Absolute-ENCODER SID, which enables the most reliable readout of a mechanical index.

The RVG-ST is the smallest meter line from G10 to G25. It has a threaded connection as standard. Optionally it is also available as flange version.

The index of the RVG-ST is located in the gas area, while the RVG uses index variants outside the gas area in atmospheric air driven by a magnetic coupler.

Main features

- Meter sizes: G10 – G400
- For flow rates
0.5 m³/h to 400 m³/h
- Nominal widths DN 25 – DN 150
- Pressure ratings
PN 10/16 and ANSI 150
- Cast iron housing (GGG 40)
or aluminium housing
- High-temperature resistance
up to 4 bar for GGG 40
- Optional: double direction index SID
for universal installation and flow
direction

RVG: Rotary Gas Meters / flange connection

Technical data RVG	
Gas temperature	-20 to +60 °C
Ambient temperature	-20 to +70 °C
Operating pressure	Max. 20 bar
Protection class	IP67 (suitable for outdoor installation)
Housing	Aluminium or cast iron GGG-40; pistons made of aluminium
Metrological approval	PTB
ATEX approval	Ex-zone 1
Media	Natural gas, town gas, propane, inert gases, further gases on request
Max. error	$Q_1 = 0.2 \quad Q_{max}$ for measuring range $\leq 1:20$ $\pm 1\%$ for $Q_1 - Q_{max}$ $\pm 2\%$ for $Q_{min} - Q_1$
Reproducibility	< 0.1%
Applicable standards	EN 12480, DIN EN 13463-1 and -5, EN 50020:2002
Index variants	S1 (standard), Double direction index SID, Absolute-ENCODER SID (option)
Outputs	Retrofitable LF-Pulsar IN-Sxx (Reed switch) Retrofitable LF-Pulsar IN-W11 (Wiegand sensor, option) HF-pulsar A1K (option)
Pressure/temperature tapping	2 pressure tappings 1/4" NPT, 2 thermowells applicable

Measuring ranges: according to PTB approval: Z 7.130 95.06

Size	Measuring chamber [dm³]	Start-up flow rate [m³/h]	Q_{min} [m³/h] national 1:160	Q_{min} [m³/h] National 1:100	Q_{min} [m³/h] National 1:65	Q_{min} [m³/h] EU-Norm 1:20	Q_{max} [m³/h]	2xNF [imp/m³]	HF* [imp/m³] (Option)
G 16 DN 50	0.56	0.03				1.3	25	10	~ 14025
G 25 DN 50	0.56	0.03			0.6	2.0	40	10	~ 14025
G 40 DN 50	0.56	0.03		0.6	1.0	3.0	65	10	~ 14025
G 65 DN 50	0.56	0.03	0.6	1.0	1.6	5	100	10	~ 14025
G 100 DN 80	1.07	0.05	1.0	1.6	2.5	8	160	1	~ 7528
G 160 DN 80	2.01	0.1	1.6	2.5	4.0	13	250	1	~ 3882
G250 DN100	2.54	0.3	2.5	4.0	6.0	20	400	1	~ 3178
G400 DN100	3.65	0.4	4.0	6.5	10	32	650	1	~ 2191
G400 DN150	3.65	0.4	4.0	6.5	10	32	650	1	~ 2191

* stated HF pulse values nominal, Specific values can deviate

Double direction index SID (option)

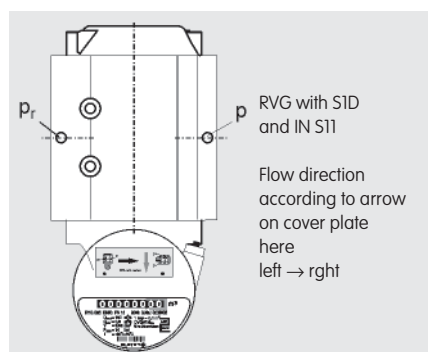

Horizontal flow: Reading from top

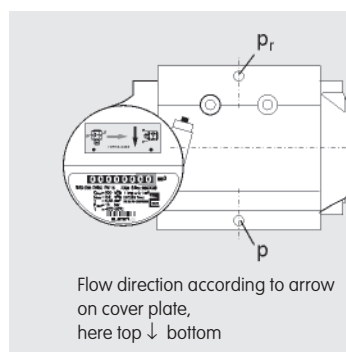

Vertical flow: Reading from the front

Upper index covered, lower free
When flow direction bottom ↑ top cover is turned round, upper index is free, lower index covered pr-offtake always at inlet

Absolute-ENCODER SID

- Electronically readable mechanical double index
- PTB and ATEX approval

For detailed information please see data sheet "Absolute-ENCODER S1"



LF pulser E1 and PCM

Elster-Instromet RVG rotary meters are commonly equipped with 2 low-frequency (LF) pulse generators and an additional monitoring reed switch (PCM) for detection of line break or interferences caused by magnetic fields. These pulse generators are attachable and can be retrofitted or changed without opening totalizer.



Installation

Installation of the pulse generator IN-S1x:

- Both guides of the IN-S1x are inserted into the guiding grooves of the totalizer head.
- Push the unit over the safety clip of the totalizer head until the IN S1x locks acoustically.

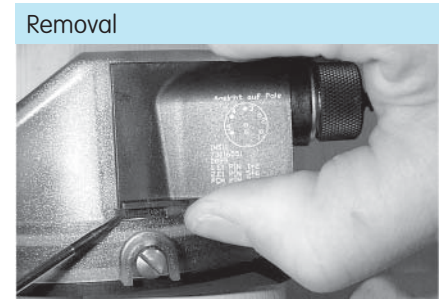

Removal

Removal of the pulse generator IN-S1x:

- Lift the lower clip of IN-S1x by means of a screwdriver and, by pulling slightly, re-move from the guide of the totalizer head.

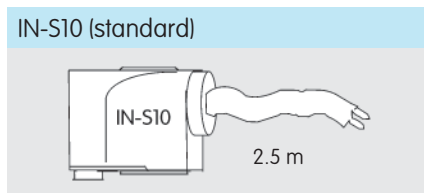

IN-S10: Wiring colours

- 1. E1: white-brown
- 2. E1: green-yellow
- PCM: grey-pink
- PCM monitoring against manipulation

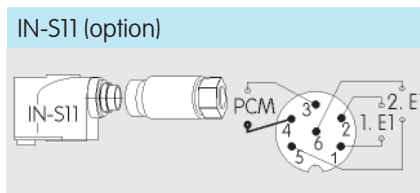

IN-S11 (option)

View on soldering side of plug socket including 1 each 6-pin female plug socket PG 9 DIN 45322

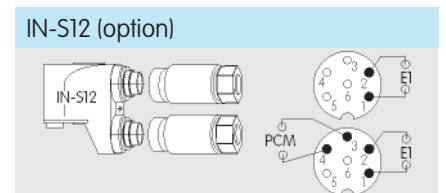

IN-S12 (option)

View on soldering side of plug socket including 2 each 6-pin female plug sockets PG 9 DIN 45322

LF-pulser: voltage: $U_{max} = 24 \text{ V}$; current: $I_{max} = 50 \text{ mA}$; switching capacity: $P_{max} = 0.25 \text{ W}$ resistor: $R_1 = 100 \Omega \pm 20\%$

The PCM control contact is a special Reed switch. In the control state, this switch is closed with a protection resistor $R_1 = 100 \Omega$ in series. When an external

magnetic field is brought into contact with the IN-S1x pulser (tampering to suppress the pulses originating from the gas flow) the Reed switch is opened. If the

switch is permanently monitored (e.g. by Elster-Instromet volume conversion devices), it is possible to recognize the exact time of line break or tampering.

LF pulser IN-W11

As an option, it is possible to fit Elster-Instromet RVGs with the Wiegand sensor module IN-W11 instead of the LF pulser module IN-S1x. The IN-W11 is

a low-frequency pulser with a definite pulse width $> 50 \text{ ms}$, which is highly reliable and ensures there is no mechanical wear and tear.

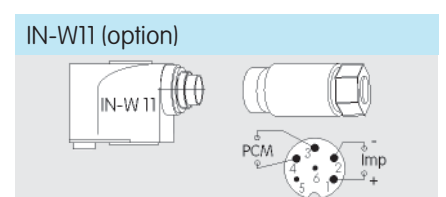

HF pulser AIK

The indicated pin assignments show:

- The view on the pin contacts of the built-in flange connector or
- The view on the soldered connection ends of the adapter socket

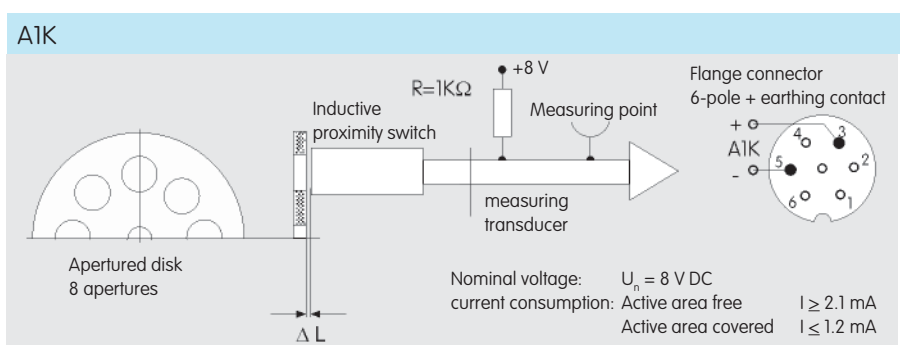

RVG: Rotary Gas Meters / flange connection

Thermowell

Prepared for two thermowells type EBL 67
(for temperature sensors up to Ø 6mm).

Pressure loss diagram

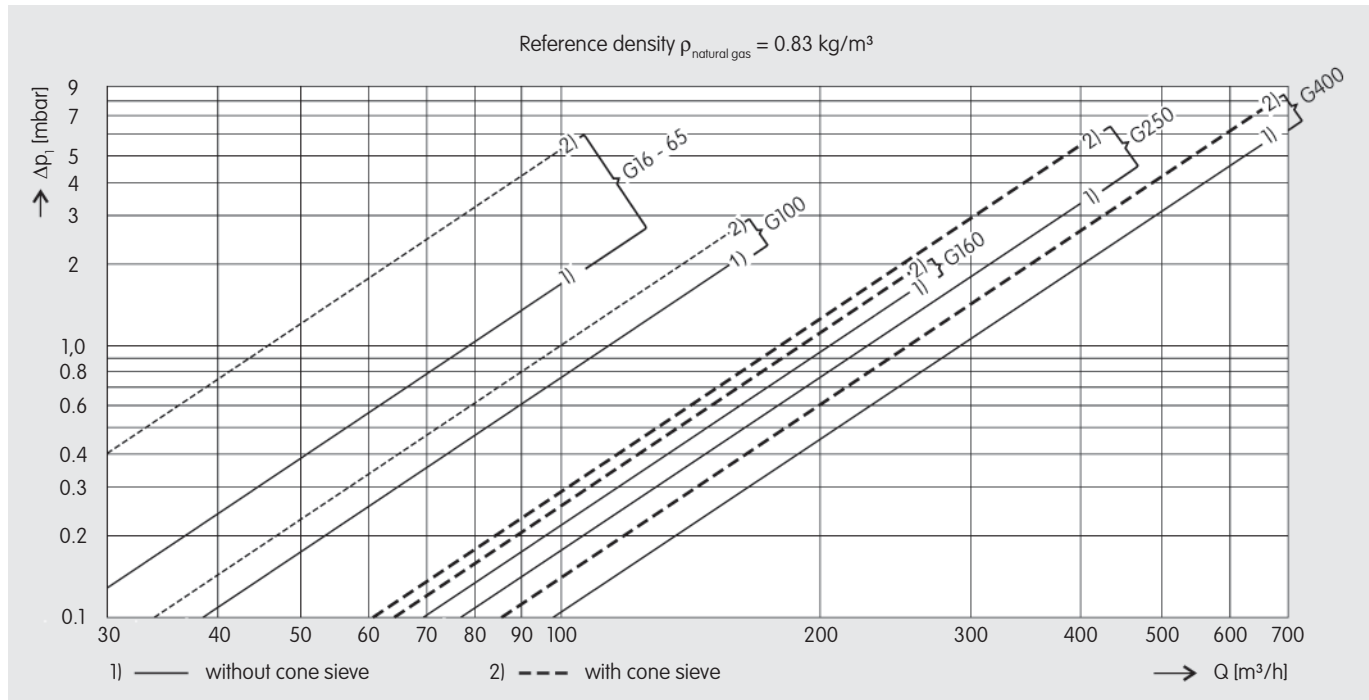

Example

Example to determine the pressure loss under operating conditions

Given:

- Load 400 m³/h
- Type G 250, DN 100
- Operating pressure 10 bar
- Gas: natural gas or air

From the diagram:

$$\Delta p_1 = 3.35 \text{ mbar (natural gas at 1 bar abs.)}$$

$$\rho_b = 0.83 \cdot \frac{11}{1} = 9.13 \frac{\text{kg}}{\text{m}^3}$$

$$\Delta p_b = 3.35 \cdot 9.13 = 30.6 \text{ mbar for natural gas}$$

Conversion for any gas (here air):

$$\Delta p_{\text{air}} = 30.6 \cdot \frac{1.29}{0.83} = 47.56 \text{ mbar}$$

Pressure loss under operating conditions:

$$\Delta p_b = \Delta p_1 \cdot \rho_b$$

Density under operating conditions:

$$\rho_b = \rho_n \cdot \frac{p_b}{p_{\text{atm}}}$$

Pressure loss for any gas G:

$$\Delta p_G = \Delta p_{\text{ng}} \cdot \frac{\rho_G}{\rho_{\text{ng}}}$$

Densities ρ_n in standard condition

Air	1.29 kg/m³
Town gas	0.64 kg/m³
Natural gas	0.83 kg/m³
Nitrogen	1.25 kg/m³
Methane	0.72 kg/m³
Propane	2.01 kg/m³
Carbon dioxide	1.98 kg/m³
Hydrogen	0.09 kg/m³

Sign	Description	Einheit
ρ_b	Density in operating condition	kg/m³
ρ_n	Density in standard condition	kg/m³
ρ_G	Density of any gas	kg/m³
ρ_{ng}	Density of natural gas	kg/m³
p_{atm}	Absolute atmospheric pressure	bar
p_b	Absolute operating pressure (overpressure)	bar
Δp_1	Pressure loss for natural gas at 1 bar	mbar
Δp_b	Pressure loss for natural gas at operating conditions	mbar
Δp_{ng}	Pressure loss for natural gas	mbar
Δp_G	Pressure loss for any gas	mbar

Flow direction

left → right

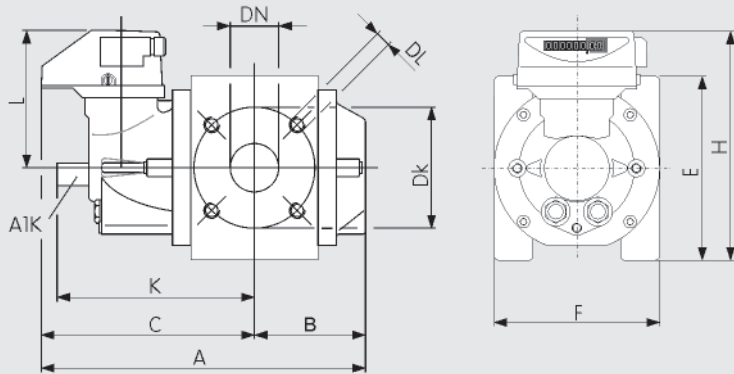

Reading from left or from top

vertikal: oben → unten

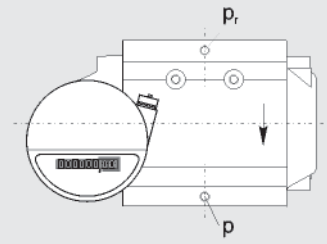

Axis roller index: horizontal
Reading from the front

Dimensions and weights

Aluminium (Dimensions in mm; weight in kg)

Size	DN *	DN **	A	B	C	H	Dk	DL	E	K	L	F	Weight
G 16	50	40	335	115	220	222	125	4 x M16	180	240	141	171	12
G 25	50	40	335	115	220	222	125	4 x M16	180	240	141	171	12
G 40	50	40	335	115	220	222	125	4 x M16	180	240	141	171	12
G 65	50	40	335	115	220	222	125	4 x M16	180	240	141	171	12
G 100	80	-	435	165	272	222	160	8 x M16	180	290	141	171	16
G 160	80	100	469	189	280	278	160	8 x M16	220	298	168	241	33
G 250	100	80	529	219	310	278	180	8 x M16	220	328	168	241	39
G 400	100	-	660	290	370	278	180	8 x M16	220	421	168	241	50
G 400	150	100	660	290	370	308	240	8 x M20	285	421	168	260	56.5

* Standard ** Special model *** Special dimensions in parentheses (at GGG-40)
Standard: Flange PN 10/16 according to DIN 2633; optional: ANSI 150 according to ASME B16.5

GGG-40 (Dimensions in mm; weight in kg)

Size	DN *	DN **	A	B	C	H	Dk	DL	E	K	L	F ***	Weight
G 16	50	40	335	115	220	222	125	4 x M16	180	240	141	150	23
G 25	50	40	335	115	220	222	125	4 x M16	180	240	141	150	23
G 40	50	40	335	115	220	222	125	4 x M16	180	240	141	150	23
G 65	50	40	335	115	220	222	125	4 x M16	180	240	141	150	23
G 100	80	-	435	165	272	222	160	8 x M16	180	290	141	240(230)	34
G 160	80	100	469	189	280	278	160	8 x M16	220	298	172	241	64
G 250	100	80	529	219	310	278	180	8 x M16	220	328	172	241	72

Adjustment to the flow direction with standard index S1

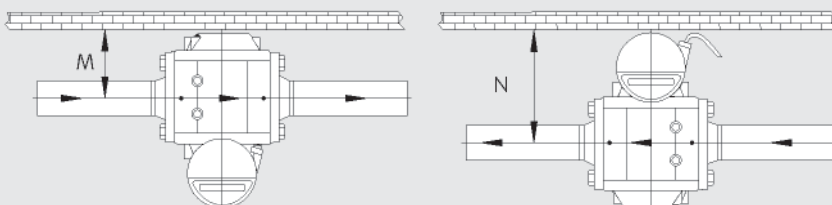

Minimum wall clearance: M or N in mm

	M	N	N with Hf pulser
G 16 - G 65	120	190	250
G100	170	240	300
G160	200	245	310
G250	230	285	340
G400	305	350	435

RVG-ST

Rotary gas meter G 10 - G 25



Compact cabinet solution with M2R

Main features RVG-ST

- Meter sizes G10 – G25
- Flow rates from 0.5 – 40 m³/h
- Nominal widths
DN 25, DN 32, DN 40, DN 50
- Line pressure maximum 20bar
- Aluminium housing



with volume corrector EK210



Ultimate system:
RVG-ST + EK210 + MR 25 G6

- Smallest space required
- Highest measuring accuracy
- Highest outlet pressure control

Dimensions

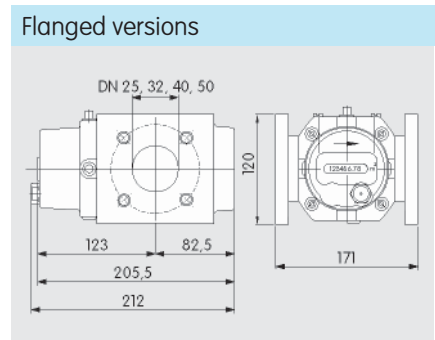
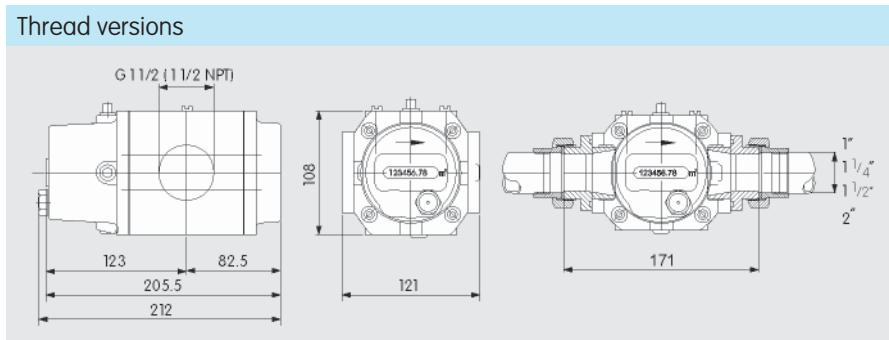

Technical data RVG-ST			
Size	G10	G16	G25
Q_{min} (m ³ /h)	0,5	0,5	0,5
Q_{max} (m ³ /h)	16	25	40
Rangeability	1 : 20 to 1 : 30	1 : 20 to 1 : 50	1 : 20 to 1 : 80
Flow range	0.5 – 40 m ³ /h		
Start-up flow rate	0.03 m ³ /h (0.5 l/min)		
Gas temperature	-20 °C to +60 °C		
Ambient temperature	-20 °C to +70 °C		
Line pressure (gauge)	Maximum 20 bar		
Protection class	IP67 (suitable for outdoor installation)		
Housing	Aluminium; pistons made of aluminium		
Metrological approval	PTB		
ATEX approval	Ex-Zone 1		
Media	Natural gas, propane, inert gases		
Max. error: ± 1 % for $Q_i - Q_{max}$ ± 2 % for $Q_{min} - Q_i$	$Q_i = 0,2 \quad Q_{max}$ for measuring range $\leq 1:20$ $Q_i = 0,15 \quad Q_{max}$ for measuring range $> 1:30$ $Q_i = 0,1 \quad Q_{max}$ for measuring range = 1:50 $Q_i = 0,05 \quad Q_{max}$ for measuring range $> 1:50$		
Applied standards	EN 12480, DIN EN 13463-1 and -5, EN 50020:2002		
Index	8-digit roller index, reading from the front		
Outputs	LF Reed contact E1 - Standard: 1 contact (pulse value = 10 pulses/m ³) + PCM* - Option: 2 contacts (pulse value = 10 pulses/m ³) + PCM* HF pulser (option) - 1 HF pulser (pulse value = 2500 pulses/m ³) according to DIN EN 50227 (Namur) Equipment: 1 HF-pulser + 1 LF-reed contact + PCM*		
Pressure/temperature tapping	2 pressure tappings 1/4" NPT, 2 thermowells applicable		
Pipe connection	- Pipe thread ISO 228, G 1 1/2 (internal thread), adaptable to pipes DN 25 (1"); DN 32 (1 1/4"); DN 40 (1 1/2"), DN 50 (2") - Flanged connection DN 25, DN 32, DN 40, DN 50 according to DIN 2633 and ASME B16.5		
Mounting	Horizontal or vertikal		
Flow direction	Left → right; right → left; top → bottom; bottom → top must be specified in the order		
Weight (kg)	4.5		

* PCM: Überwachungskontakt gegen Manipulation

LF pulser E1

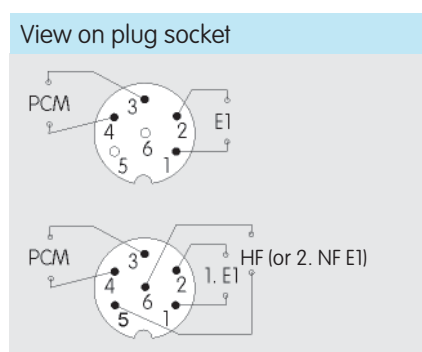

Standard:
LF-pulser E1 (Reed-contact)
and PCM supervision contact
against tampering

Option:
HF - LF pin assignment

RVG-ST: Rotary Gas Meters G10 - G25

Connecting sets

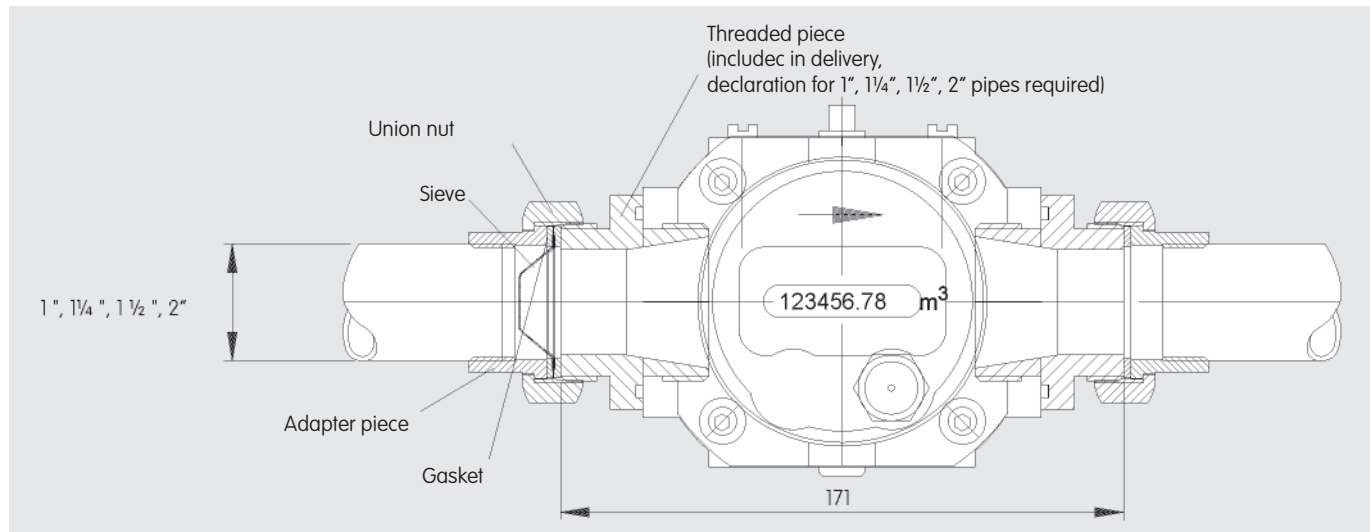

Optional available are connecting sets

consist of:

3 x gasket

1 x sieve

2 x adapter piece

2 x union nut

für 1" pipes with outside thread No. 730 176 52

für 1 1/4" pipes with outside thread No. 730 176 53

für 1 1/2" pipes with outside thread No. 730 176 54

für 2" pipes with outside thread No. 730 181 60

Pressure loss diagram

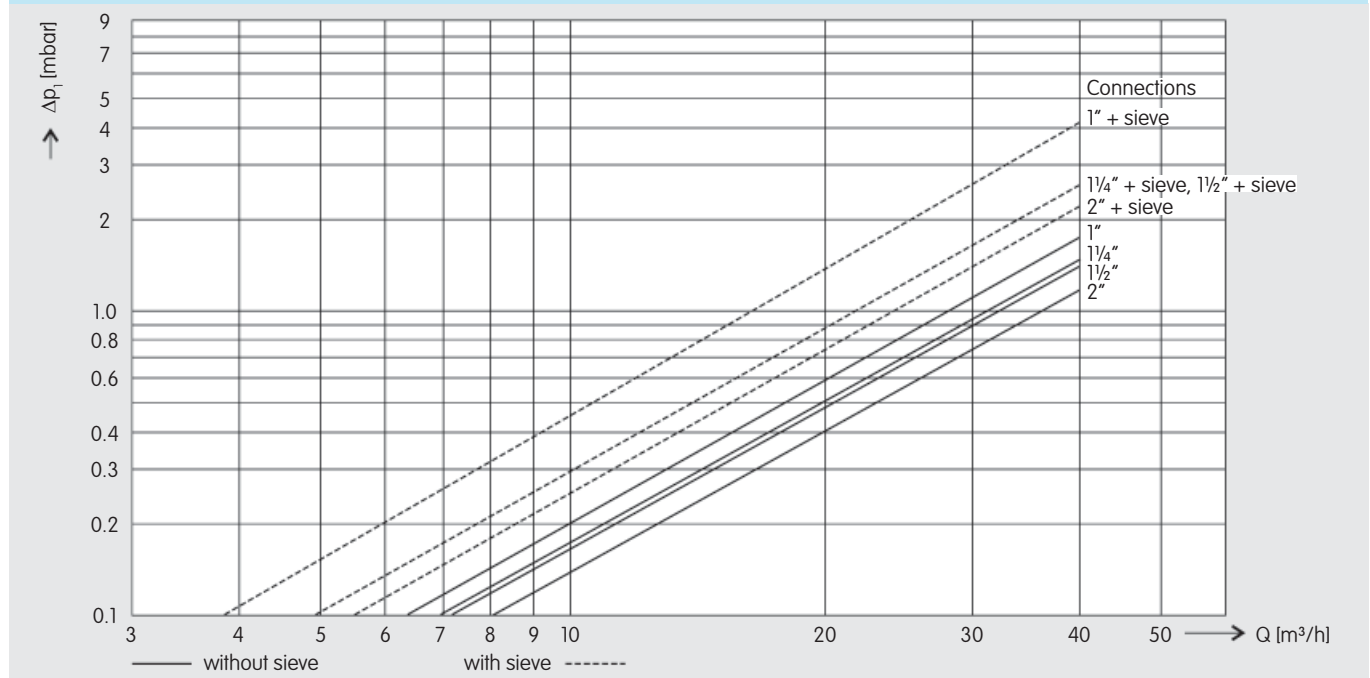

Your contacts

Germany
 Elster-Instromet GmbH
 Steinern Str. 19 - 21
 55252 Mainz-Kastel
 T +49 6134 605 0
 F +49 6134 605 223
 www.elster-instromet.com
 info@elster-instromet.com

RVG EN01

A31.08.2007

Belgium
 Elster-Instromet N.V.
 Rijkmakerlaan 9
 2910 Essen
 T +32 3 670 0700
 F +32 3 667 6940
 www.elster-instromet.com
 info@elster-instromet.com

Singapore
 Elster-Instromet
 Singapore Representative Office
 80 Marine Parade Road
 09-04 Parkway Parade
 Singapore 449269
 T +65 6247 7728
 F +65 6247 7729